

Development of a low cost hydroponics system and a formulation for the tropics

M.D.J.S. Saparamadu¹, W.A.P. Weerakkody², R.D.Wijesekera¹ and H.D. Gunawardhana¹

¹Department of Chemistry, University of Colombo, Colombo 03, Sri Lanka. ²Department of Crop Science, Faculty of Agriculture, University of Peradeniya, Peradeniya, Sri Lanka. E-mail: mdsap@ou.ac.lk

Abstract

Simplified hydroponics is a low cost aggregate hydroponics system which is practiced under natural climatic conditions with hand watering. Rice hull is a waste material which is not properly utilized and a mixture of rice hull and sand (3:2) was used in this system. A new nutrient formulation (NF) was developed using locally available commercial grade chemicals. A buffer system was incorporated to the nutrient formulation, ensuring that the pH was maintained in the optimum range. NF was composed of (in ppm), N = 167, P = 80, K = 281, Ca = 234, Mg = 57, S = 251, Cu = 0.01, Fe = 3.9, Zn = 0.13, Mn = 1.2 and Mo = 0.13. A field trial was carried out for NF in the wet zone in Sri Lanka for tomato plants in simplified hydroponic system. The nutrient uptake was monitored by measuring the change in weekly average electrical conductivity (EC) of the root solution (compared to the EC of the applied nutrient) of tomato plant beds. The pH of the root solution was in the suitable range and no adjustment was required indicating successfulness of the buffer in the formulation. The nutrient cost involved to produce 1 kg of tomato was about 70% less than other commercially available nutrients.

Key words: hydroponics nutrients, hydroponics nutrient for tomato, hydroponics in tropics

Introduction

There is a need for low cost, readily available, simple, attractive technologies which can utilize space and water efficiently and also low cost nutrient packs in order to increase the productivity in agriculture. Modern hydroponic systems are high-tech operations, with fully computerized and automatic control of solution pH and electrical conductivity (EC), air and solution temperature, nutrient analysis, etc. These need special equipment for pumping, circulating, flowing, misting, dripping, etc. of nutrient solution.

In recent years, hydroponic system which does not require costly facilities, high running cost and intensive care have been developed in different parts of the world. These have major characteristic—the nutrient solution stays in the production boxes until harvest and is not circulated nor re-adjusted. Now, the benefits of hydroponics is within reach of ordinary farmers and gardening enthusiasts, even in off-grid areas, marginal lands, or tight city spaces. Simplified hydroponics systems have been designed which cuts down the cost to a minimum by requiring no instruments, no expensive media or growing units. A suitable nutrient formulation will maintain a suitable pH, EC and will be of sufficient ratios of elements required for a particular growth stage. By measuring pH and EC and conducting regular nutrient analysis throughout the life cycle of the crop, it will be possible to determine whether the quantities and the ratios of elements in the nutrient solution applied is sufficient for each growth stage under the prevailing climatic conditions. Therefore, the objective of this study was to introduce low cost hydroponic system and a nutrient formulation for the tropics.

Materials and methods

System: A mixture of rice hull (fermented for a week and washed) and river sand (washed) in the ratio of 3:2 was used as the medium

in the system (Fig. 1). Leaching studies using this mixture were carried out in the laboratory, simultaneous to the field experiment to ensure that the medium is inert.

Preparation of the low cost nutrient formulation: The nutrient formulation was prepared as indicated in Table 1.

Field Experiment: The field experiment was conducted in the Western Province of Sri Lanka (Agro-ecological zone of Low Country Wet Zone) during September, 2006 - February, 2007. Tomato (*Lycopersicon esculentum* Mill.), variety Thilina plants were grown in the simplified hydroponics aggregate system (Fig. 1). Irrigation and fertigation was done as specified in the Table 2. Each treatment plot (growing bed) had six plants. The Table 1. Quantities of the solid pack of new nutrient formulation required to make 50 dm³ of nutrient solution

Item	Compounds	Amount
Pack A	Ca(NO ₃) ₂ .4H ₂ O	49.7 g
Pack B	KNO ₃	16.5 g
	MgSO ₄ .2H ₂ O	27.35 g
	CaSO ₄ .2H ₂ O	7.25 g
	FeSO ₄ .7H ₂ O	1.54 g
Concentrated micro nutrient solution	MnSO ₄ .4H ₂ O, 3.44 g and	50 cm ³
	CuSO ₄ .5H ₂ O, 0.66 g in 1 dm ³	
Concentrated buffer solution	H ₃ PO ₄ 170 cm ³ (200 g / dm ³) and KOH 600 cm ³ (63.51 g / dm ³) in 1 dm ³	250 cm ³

Table 2. Fertigation procedure

Growth stage	Amount added (dm ³ / bed)	Frequency of application
Seedling	1.5	Once in 3 days
Growing	1.5	Once in 2 days
Flowering	1.5	Daily
Fruiting	1.5	Daily

experimental lay-out was covered with a transparent plastic shelter. Weather parameters, EC and pH of the solution in the growing bed and the amount of nutrient applied and the yield were recorded. Nutrient solutions (before application) and the root solutions in the beds (at weekly intervals) were analyzed in order to calculate the amounts of nutrients absorbed by plants. This procedure was adopted weekly for the entire life cycle of the plants.

Results and discussion

The system: Simplified hydroponics system is practiced in natural climatic conditions with any discarded container (in which no poisonous material has been stored) using waste or low cost substances as media. Fertigation is carried out manually and the nutrients and water are conserved by a simple mechanism so that the water is used efficiently. Since there is no elution of nutrient excess, environment pollution is minimal. Rice hull is a waste material and it's characteristics such as light weight (density 0.12 - 0.13 g/cm³), inertness, good drainage, high aeration, low rate of decomposition and low water holding capacity (WHC) makes it a suitable medium (Bradley, 2000). The results of the leaching studies indicated that this medium could be considered to be inert with respect to adsorption and desorption of nutrients.

Nutrient formulation: After studying the formulations used under similar climatic conditions, the following compounds were selected considering their solubility, availability in the local market and also the cost: KNO₃, H₃PO₄, KOH, MnSO₄·4H₂O, FeSO₄·7H₂O, CuSO₄·5H₂O, MgSO₄·7H₂O, H₃BO₃, K₂SO₄. Analysis of the commercial grade chemicals indicated that they contained only a very low percentage of un-dissolved solids while no heavy metals were detectable. This is of importance because un-dissolved solids may lead to blockage of the draining tubes and make the availability of plant nutrients lower than the expected levels. Toxic metals could be introduced to humans on consumption of the edible parts of the plant leading to health problems. Additional sources of zinc and molybdenum were not required since they were provided by the commercial grade chemicals used as macro element sources. Therefore, only the amounts of micro nutrients required additionally were supplied by the commercial grade compounds, *i.e.* micro nutrient sources, iron (II) sulfate, copper sulfate and manganese sulfate. The advantage of using a KOH / KH₂PO₄ buffer system is that it supplies part of the requirement of K to the plants in addition of maintaining the pH.

The composition of the new formulation is given in Table 3. In

Table 3 Compositions of the new formulation

Macro element	Formulation NF (ppm)	Micro element	Formulation NF (ppm)
Ca	234	Cu	0.10
N	167	Fe	3.6
P	80	Zn	0.14
K	281	Mn	1.2
Mg	57	Mo	0.13
S	251		

Table 4. Changes in the weekly average EC in the root solutions in tomato beds

No of weeks after transplanting	Change in the weekly average* EC (mS/cm)	No of weeks after transplanting	Change in the weekly average* EC (mS/cm)
1	+1.38	8	+1.67
2	+1.51	9	+1.86
3	+1.34	11	+2.18
4	+1.63	12	+1.44
5	+1.59	13	+0.73
6	+1.44	16	+0.15
7	+1.56	17	+1.18

* The change was calculated by deducting the average EC in the root solution from the nutrient applied.

Table 5. Nutrient cost of NF for tomato plants

Amount of NF used (kg)	Cost for nutrients (Rs.)	Total yield (kg)	Cost of NF to produce 1 kg of tomato (Rs.)
1.48	202.00	5.8	35.00

order to make sure that the expected amounts of ions are available to the plants, the working solutions were prepared directly rather than by diluting stock solutions. A concentrated micro nutrient solution was prepared as it would be more homogeneous compared to a solid mixture. Large quantities can be measured accurately.

Field experiment: During the experiment, the temperatures of both day (26 - 32 °C) and night (25 - 27 °C) were not in the optimal range for growth of tomato. The relative humidity (66 - 96 %) was in the optimum range on most days. The change in the weekly average EC of the root solution of tomato plant beds compared to the EC of the applied nutrient was significant throughout the life cycle of tomato, indicating that nutrients are being absorbed by the plants at significantly high rates (Table 4 & Fig. 2). The pH of the plant beds were in the favorable range, 5 - 7.5 throughout their life cycle. The average yield/ plant was 320.2 (g) which was compatible with that of a normal soil grown plant for which it is 325 g/plant.

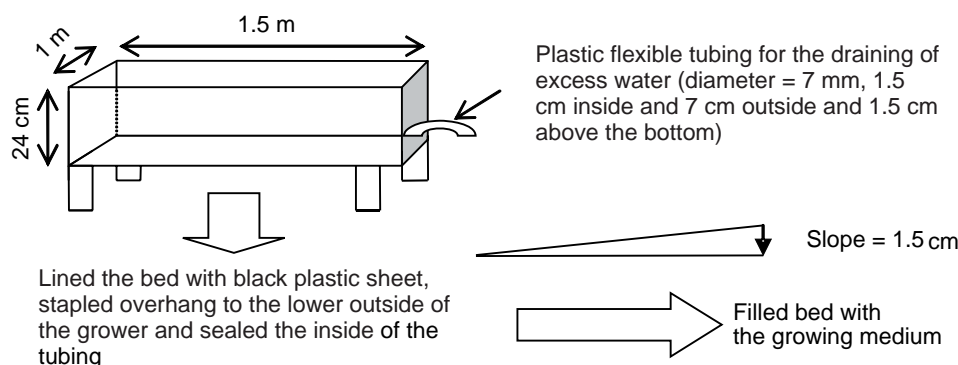

Fig.1 Simplified hydroponics system (Source: Bradley & Marulanda , 2000)

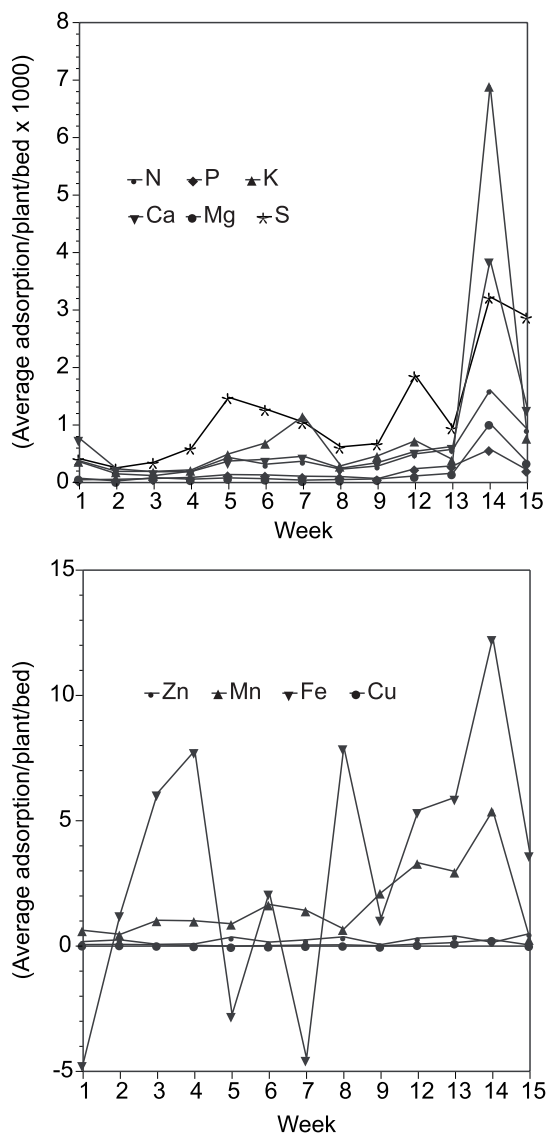

Fig. 2 Absorption patterns (uptake concentration) of macro elements in tomato plants

The cost of chemicals to prepare 1 kg of NF was Rs.220.00, which is about 38% less than that of the other commonly used commercially available nutrients in Sri Lanka. Further, the amount of the new nutrient formulation required to produce 1 kg of tomato was about 20% less compared to the other commercially available nutrients in Sri Lanka (Table 5).

Absorption patterns: The absorption of all the macro elements by tomato plants of treatment NF was significantly higher at the 14th week after transplanting (fruiting stage) (Fig. 2) and it is evident that an adequate amount of these elements are available thus provided by the new formulation for all the growth stages of the plants.

This study suggests that simplified hydroponics system with a mixture of rice hull and sand (3:2) was as productive as conventional soil grown tomato under the natural climatic conditions in Sri Lanka. The new nutrient formulation is cost effective compared to the other commonly used commercially available nutrient packs in Sri Lanka. The amount and the frequency of irrigation and nitrification were less in this system. Field trials might need to be carried out under different climatic conditions and during different periods of the year in order to find out the optimum natural conditions under which the new nutrient formulation is more productive. The new formulation may be used on other fruiting and leafy vegetables to evaluate its performance on other crops.

Acknowledgements

CARP grant (No. 12/624/473) is gratefully acknowledged. We are thankful to the Department of Chemistry, University of Colombo for providing the facilities to carryout the research work.

References

- Bradely, P. 2000. Introducing popular hydroponics gardens in Senegal. *The growing Edge*, 11 (3): 62-71.
- Bradley, P. & C. Marulanda, 2000. *Home Hydroponic Gardens*, Institute for Simplified Hydroponics, Box 151, Corvallis, Oregon 97339.
- Morgan L. 2000. *The best of Growing Edg: Electrical conductivity*, A. Knutson (ed.), New Moon .Publishing Inc., Corvallis, OR 97339.
- Ranasinghe, R.A.S. and W.A.P. Weerakkody, 2006. Effects of fertilizer dosage and nutrient balance on growth, yield and nutrient uptake of greenhouse tomato grown in grow-bag culture. *Trop. Agri. Res.*, 18: 394-398.
- Smith R. 2000. *The Best of Growing Edge: Plant nutrients*, A. Knutson (ed.), New Moon Publishing Inc., Corvallis, OR 97339, USA.
- Tisadale S.L., W.L. Nelson, J.D. Beaton and J.H. Havlin, 1993. *Soil Fertility and Fertilizers*, 5th Ed., Macmillan Publishing Company, New York 10022.