

Design of a mobile device charger using a Stand-alone PV System

P. W. D. M. Fernando, R. H. G. Sasikala*

Department of Electrical and Computer Engineering, The Open University of Sri Lanka, Nawala, Nugegoda, Sri Lanka

*Corresponding Author: email: rhsas@ou.ac.lk, Tele: +94112881272

Abstract – *Stand-alone photovoltaic (PV) systems with battery banks are ideal for remote rural areas and applications where other power sources are either impractical or are unavailable. The solar-powered mobile phone charging station is considered as one of the stand-alone PV systems invented as the solution for mobile travellers to charge their mobile devices since portable batteries or DC buses are not commonly available among the general public.*

The major problem with the photovoltaic charging system is the energy conversion efficiency of solar panel and load fluctuation. Therefore, to provide continuous electrical power supply to the load, a storage facility must be used. The efficient charging system is required with lesser charging time to store solar energy within the battery. This study proposed implementing a 12 V DC bus with a stand-alone PV system, including voltage reference Maximum Power Point Tracking (MPPT) system and a battery backup. This would be an alternative to the above-mentioned solar-powered mobile charging station considering the cost, accessibility and mobility.

Therefore, the proposed system used a control circuit to manage the output power of the solar panel. It used the fractional open circuit voltage MPPT algorithm, and as necessary it controls the voltage by checking the load conditions. This system mainly consists of two DC-DC buck converters, 50 W solar panel, microcontroller, 12 V battery, controllable switches and USB ports to connect the mobile device for charging. The controller unit does MPPT process and PWM generation, battery monitoring for overcharging and over discharging process.

The proposed stand-alone PV system is equipped with 12 V DC bus and two 5V USB ports that can be used to charge the mobile phones, pad, iPhone and tablets etc. This system can be used in places such as bus stands and communities inaccessible to the national grid. At the emergencies, people can charge their mobile devices only using the USB cable. The proposed system can be used throughout the day since the system equipped with a battery backup.

Keywords: *Buck converters, maximum power point tracking, photovoltaic systems, voltage reference*

1 INTRODUCTION

Solar energy is one type of renewable energy, which plays a significant role in the present energy market. Converting solar energy to electrical energy is one form of the application using grid-connected and off-grid electricity systems. The photovoltaic systems which use solar panels are most popular as stand-alone PV systems at present. The solar-powered mobile phone charging station is considered one of the stand-alone PV systems invented as the solution for travellers to charge their mobile devices since portable batteries or DC buses are not commonly available among the general public. The major problem with the photovoltaic charging system is the energy conversion efficiency of

solar panel and load fluctuation. Solar panels convert solar energy directly into the electricity. Ordinarily, solar panels convert 15% - 20% of energy incident on it into electrical energy (Agrawal and Tiwari, 2011). The output of the solar cell does not have the linear V-I characteristic. According to the climate, solar radiation varies from time to time; hence, the solar panel's energy fluctuates. Also, the demand from the load does not always equal to the solar panel capacity. Therefore, to provide continuous electrical power supply to the load, a storage facility is required. The efficient charging system is required with lesser charging time to store solar energy within the battery. Most of the systems used the Maximum Power Point Tracking (MPPT) system to get the maximum output from the solar panel. The maximum power extracted from the PV panels depends mainly on three factors such as irradiation, ambient temperature and the load.

Nowadays, there are vast numbers of houses having rooftop solar systems as net metering. The problem is when installing the rooftop solar systems total panel capacity is selected much greater than the chosen inverter capacity. The oversizing of solar panels increases energy production because usually panel does not produce its rated power and commonly PV systems used the MPPT to extract the maximum power from the panels. Because of this extra sizing of panels, inverters can run at higher efficiency. But rarely at right weather conditions, these panels produce the rated power. This will not be a problem if the sizing of panels considers the power tolerance of the inverter. But most of the systems do not assess the inverter stability and hence always system is always disconnected when sensing the overvoltage. Actually, at that time energy is available but cannot be extracted because the system is already disconnected. Therefore, we can't extract the available power. It is a waste of energy. By introducing a battery charging with a stand-alone PV system, this paper suggests a method to use that available power in the PV system.

This study proposed implementing 12 V DC bus with a stand-alone PV system, including voltage tracking MPPT (Maximum Power Point Tracking) system and a battery backup. This would be an alternative to the above-mentioned solar-powered mobile charging station considering the cost, accessibility and mobility. This system uses a control circuit to manage the output power of the solar panel by checking the load condition.

The proposed stand-alone PV system is mainly included with 12 V DC bus and additional two 5 V USB ports which can be used to charge the mobile phones, pad, iPhone and tablets etc. This system can be used in bus stands and areas where people live without electricity access. At the emergencies, people can charge their phones only using the USB cable. The proposed system can be used in the daytime and at the night-time using the battery backup.

2 LITERATURE SURVEY

Voltage based MPPT for PV system

Ahmad (2009) and Kim (2009) describes the design of a voltage based maximum power point tracker for photovoltaic applications. This method considered as the most straightforward and cost-effective method. But in this method, it disconnected the PV array from the load for the sampling of its open-circuit voltage, which results in power loss.

MPPT system with Perturb and Observe technique

Ulaganathan, et. al, (2014) in their research paper confirm that maximum power has been extracted by P&O method irrespective of atmospheric temperature and solar irradiance

with the Arduino Microcontroller. Also, it tracks the maximum power point quickly without oscillation. In the system, it used boost converter topology to maximize the efficiency of the PV array. PV array are connected with the load by DC/DC converter. The PV array can always work at the maximum power point by adjusting the DC/DC converter's duty cycle. The duty cycle was adjusted according to the Perturb and Observe algorithm.

A Comparative Study of MPPT techniques for PV Systems

This paper has presented a comparison between ten different Maximum Power Point Tracking techniques (Faranda and Leva, 2008). Under these methods, it describes the three methods which only track the voltages. These methods have low efficiency compared to the other methods and the P&O and IC algorithms are the most efficient of the analyzed MPPT techniques. Also, it shows the experimental comparisons between different MPPT techniques, implementation cost and complexity.

Stand-alone Photovoltaic-Battery Hybrid Power system

According to the research done by Xiong (2016) on Closed-Loop Design for Standalone Photovoltaic-Battery Hybrid Power System, the system may operate in a MPPT mode or off-MPPT mode to regulate the output voltage, and at the same time, the battery may provide power to the load or store energy from solar power. The operating conditions use the nonlinear analysis method based on discrete-time mapping model and is complex.

Performance of buck and buck-boost convertor with PV system

Atallah, et. al, (2014) design a PV system with direct control the using the buck and buck-boost convertor. This module is connected to a power converter and varies the current from the PV array to the load. It says that Both buck and buck-boost converters have succeeded in tracking the MPP, but buck converter is much more effective specially in suppressing the oscillations produced due to the use of P&O technique.

MPP tracking solar charger controller with buck convertor

The Conference Paper of Design and Implementation of Maximum Power Point Tracking Solar Charge Controller represents the required calculations for selecting the buck convertor (Pathare, et. al, 2017). This demonstrate system is a low cost, low power consumption, microcontroller-based control unit with high power efficiency. This controller system is controlled using the Arduino.

Battery charging using MPPT to improve the durability of the battery

This paper presents a complete methodology for the design and construction of a stand-alone photovoltaic power supply. (Lopez, et. al, 2013). It gives the method sought to prevent the battery from a malfunction in its operation that could compromise its durability. It proposes a control strategy for the battery charging and control strategy to maximize photovoltaic energy production by incorporating an MPPT technique. According to the first region of voltage-current characteristics of the battery, the fully discharged state it is essential the photovoltaic modules' arrangement operates at the maximum power to apply the largest admissible current to the batteries to charge them in the shortest time interval possible.

3 METHODOLOGY

This study proposed implementing 12 V DC bus with a stand-alone PV system, including voltage tracking MPPT (Maximum Power Point Tracking) system and a battery backup. To achieve this, the first detailed study was carried out to identify different MPPT techniques and studied the behaviour of existing stand-alone PV systems. Also studied about the battery charger controller functions. The overall system is designed with relevant sub-sections such as designing and developing a charger controller unit with voltage tracking MPPT, design over charging protection, and over-discharging protection to the battery. Then the system is implemented as a hardware prototype and tested in real-time.

4 DESIGN OF THE SYSTEM

This system mainly consists of two DC-DC buck converters, 50 W solar panel, microcontroller, 12 V battery, controllable switches and 5 V USB ports to connect the phone for charging. MPPT process and PWM generation, battery monitoring for overcharging and over-discharging process are done by the controller unit, which is the heart of the system. It also controls the operating mode by controlling the switches.

4.1 DETAILED DESIGN OF THE PROPOSED SYSTEM

Figure 1 shows the overall system as a block representation. Fractional open circuit voltage MPPT algorithm is used due to its simplicity. Mainly there are three switches to control the 12 V output voltage from the buck converter 1. The controller unit monitors the battery conditions and if over discharging limit occurs, then disconnected the discharging path, and it does not give a chance to overcharging (Atallah, et. al, 2014). Buck converter 2 is used to step down the 12 V to 5 V for mobile phone charging purposes.

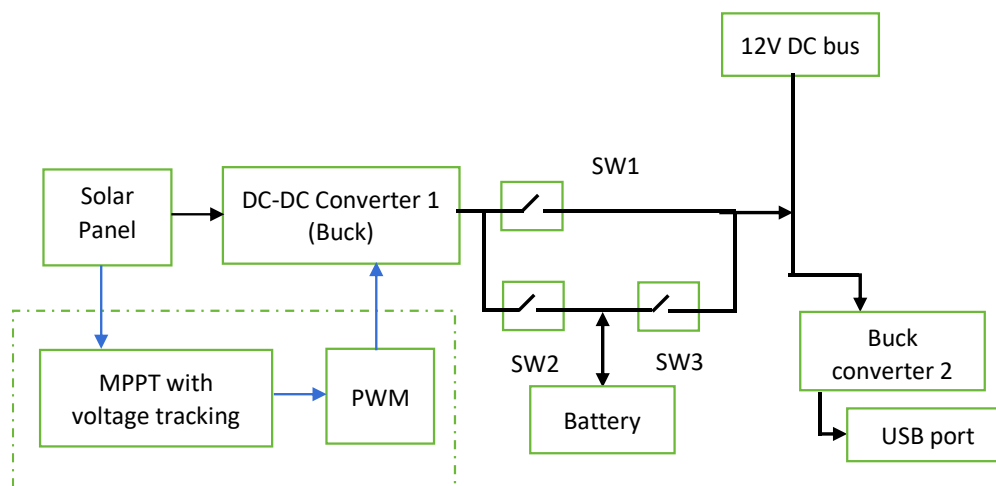

Fig. 1. Block diagram of the system

The heart of the system is the controller unit which is shown in figure 2. The controller unit does MPPT process and PWM generation, battery monitoring for overcharging and over discharging process. It also controls the ways of providing the power to the load by controlling the switches.

Solar energy is directly converted to the electricity, and this energy goes through the DC-DC buck converter to regulate the voltage. For switching purposes at the MPPT, the buck

converter needs PWM pulses. These pulses are generated from the controller circuit with respect to the MPPT process. There are different types of MPPT algorithms and among them, fractional open circuit voltage MPPT algorithm is used for this system due to its simplicity (Jyothi, et. al, 2016)

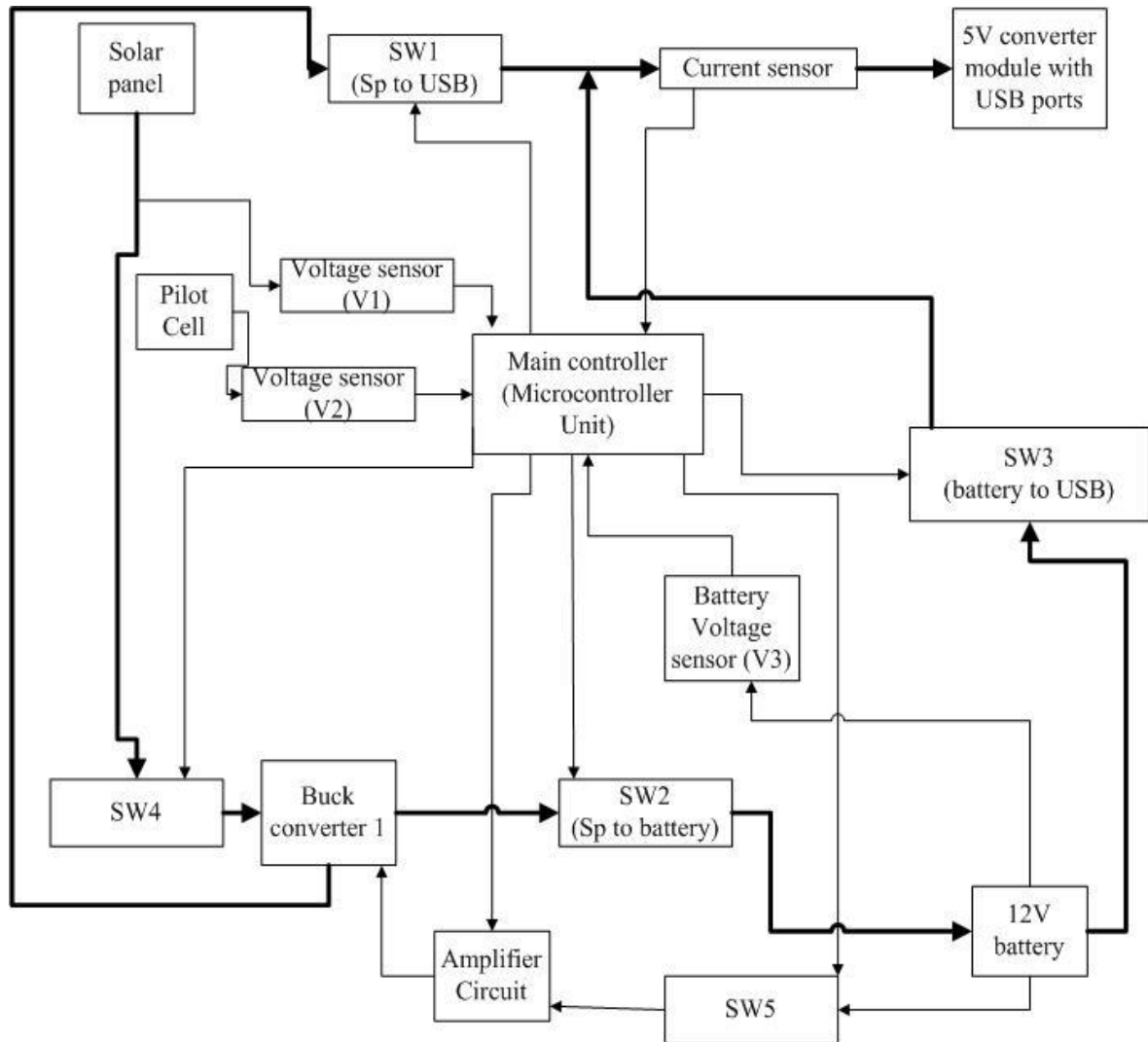

Fig. 2. Main control system

Mainly there are three switches to control the 12V output voltage from the buck converter-1. When the solar panel provides sufficient power, it can supply the load directly without discharging the battery. If the solar panel does not generate any power, then the battery can be discharged. When there is no load connected, the battery can be charged using solar energy. The controller unit monitors the battery conditions and when over discharging limit occurs, discharging path disconnected and it does not overcharge.

4.2 OPERATING MODES OF THE PROPOSED SYSTEM

The proposed system can provide four operating modes. When load connected to the system;

- Mode 1: solar PV panel directly give power to the load
- Mode 2: Load power provides by both battery and the PV.

Mode 3: Load power provides only by the battery
 When there is no load connected to the system,
 Mode 4: if the solar panel can give power, then charge the battery.

Mode 1: When the 12V battery is fully charged, PV can provide sufficient power to the load. Then it doesn't need the MPPT process.



Fig. 3. Operating mode 1

Mode 2: When 12V battery is in the float charge region, and PV produces sufficient power, it doesn't need the MPPT process. It can manage the power requirement without tracking the MPPT.

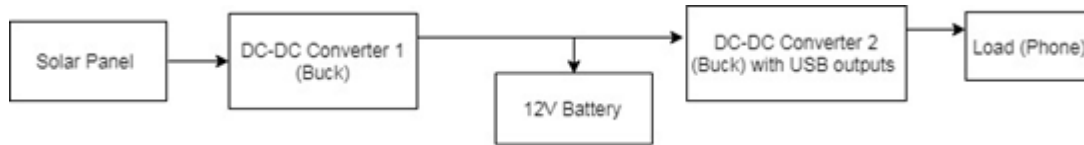

Fig. 4. Operating mode 2

Mode 3: At the night or cloudy weather PV cannot produce the power. Then the 12V battery can provide the required power to the load.

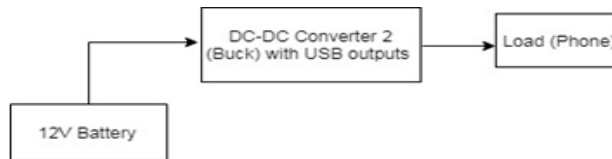

Fig. 5. Operating mode 3

When MPPT process in on mode,

Mode 4: If the 12V battery in bulk charge region. Then by providing maximum current, we can charge the battery within less time. This mode tracks the MPPT and tries to extract the maximum power from the system. Also, the system can provide the required power to the load too.

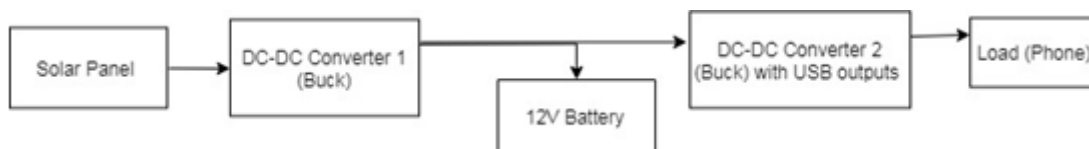

Figure 6. Operating mode 4

The solar panel is disconnected from the system when the panel voltage reaches 14.5 V. The system has IN4007 diode to protect the panel from reverse current. It is assumed that the battery never dead and State of Charge (SOC) values are selected considering the temperature values.

4.3 BATTERY CHARGING, SELECTED BATTERY AND VOLTAGE LEVELS

Proposed system used a 12V Lead-acid battery as the battery backup. Mainly lead-acid battery charging cycle has four regions, and for the proposed system first region is neglected because it is assumed that battery never dead. Battery charging regions are shown in Figure 7.

Bulk charge region: The first region is corresponding to a fully discharged battery. In this region, it can apply maximum charge current with considering the specification of the battery. This current can apply till the battery voltage reach the overcharge voltage. In this region, to apply the largest satisfactory current to the batteries to charge the battery with lesser time, MPPT can be used.

Overcharge region: This is corresponding to partially charged battery, constant charging voltage with a current limit can be used in this region. (According to the battery manufactures manual).

Float charge region: This is corresponding to the battery at almost fully charged. In this, it controls the voltage within the float voltage limit. This voltage is applied to the battery to avoid its auto discharge.

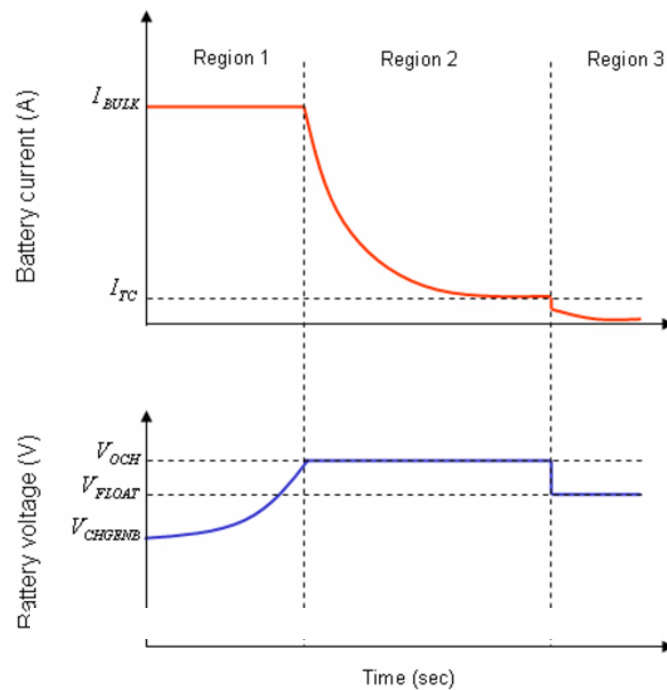

Fig. 7. Battery charging regions (L.M.F. Morais)

The 12V, 7Ah lead-acid battery is used as the storage. Since this prototype system is used to charge the phones and tablets, the battery can give 86Wh (12V x7Ah). Usually, smartphone battery consumes 10-11Wh to full charge. Thus, this battery storage is sufficient to charge approximately 8 phones fully (without considering the loss). To control the battery overcharging and over-discharging process ATmega328P microcontroller board is used(Arduino Uno Rev3,Anon., n.d)

This battery is a lead-acid battery, and let's assume as the cell voltage is 2 V and 12 V battery has the 6 number of cells. When a cell is fully charged the voltage become 2.15 V and when it discharged the voltage become 1.9 V. By considering these factors state of the charge (SOC) for the 12V battery can get as follows.

Full charged battery voltage = $2.15 \times 6 = 12.9V$

Discharged battery voltage (V_{bt}) = $1.9 \times 6 = 11.4V$

Voltage difference of cell, between charging and discharging states = $2.15 - 1.9 = 0.25V$.
 Since for 12V battery voltage difference = $0.25 \times 6 = 1.5V$.

The open circuit battery SOC = % charging

$$\% C = \frac{(V_{bt} - 11.4)}{1.5} \times 100 \quad (1)$$

Using equation (1), noted the open-circuit voltage at 30%, 80% and 100% states.

at 30% SOC = 11.85 V

at 80% SOC = 12.6 V

at 100% SOC = 12.9 V

This system battery is disconnected from the charging and discharging paths to get the open-circuit voltage every 1 minute. If the open-circuit voltage value is in-between 11.85 V and 12.6 V, then operate the MPPT process. If the voltage value is above 12.6 V, then normal charging happens. Also, if the voltage is 11.85 V, disconnect the discharging path and if the voltage is 12.9 V then disconnect the charging path.

4.4 MPPT TECHNIQUE USED FOR THE IMPLEMENTATION

Among the various techniques used to track the maximum power, voltage based maximum power point tracker (MPPT) system is used in many applications. This method is considered as the most straightforward and cost-effective method. But in this method, it disconnected the PV panel from the load for the sampling of its open-circuit voltage, which results in power loss. The proposed system fractional open-circuit voltage (FOCV) method with the pilot cell is used as the MPPT technique. Since the proposed system is used only for battery charging purposes, easy and cheap implementation is significant (Siddhant, 2014). The FOCV algorithm measured the Open circuit voltage (V_{oc}) from the pilot cell and current voltage $V_{pv}(t)$ get from the solar module. Then calculates the V_{mpp} by using the equation (2).

$$V_{mpp} = K_{oc} \times V_{oc} \quad (2)$$

where, V_{mpp} = voltage at the maximum power-point

V_{oc} =open circuit voltage of the panel

K_{oc} = constant depends on the solar panel characteristic value for the constant k is get as the 0.81. It gets by considering the solar panel specifications at the standard condition. (Irradiation = 1000 watts/m², temperature =250 °C)

After considering and comparing the V_{mpp} and $V_{pv}(t)$ it changes the voltage by increasing or decreasing the duty cycle which give to the DC-DC buck converter with considering the difference between V_{mpp} and $V_{pv}(t)$. Flow chart for the proposed MPPT algorithm is shown in Figure 8.

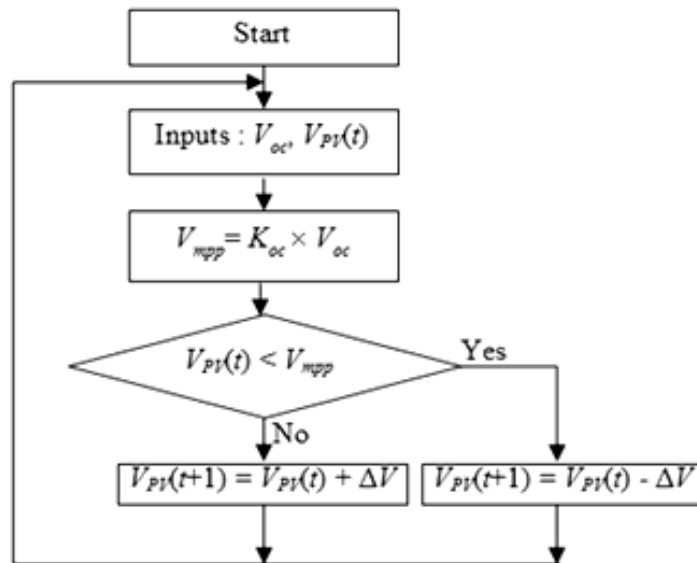

Fig. 8. Flow chart for proposed MPPT algorithm

5. SYSTEM IMPLEMENTATION

Adjustable buck converter module based on LM2596S is used as the main buck converter which has input voltage range 4.5V - 40V and output voltage adjustable from 1.23V - 37V. Fixed 5V buck converter module with two USB port is used for mobile phone charging. For the controlling unit, it used ATmega328P (ArduinoUno) microcontroller.

Pulse Width Modulation (PWM) is used in this system for the MPPT process. Adjustable buck converter module (LM2596S) used for the main buck converter block for step down the PV voltage. At the MPPT process, created PWM signals given to the feedback pin and extracted the system's maximum power. For this purpose, a small circuit which acts as the low pass filter and Op-Amp to convert the PWM signal to analog signal is used.

5.1 FABRICATION OF HARDWARE

Prototype implementation for the stand-alone PV system is shown in figure 9 and testing of the prototype is shown in figure 10.

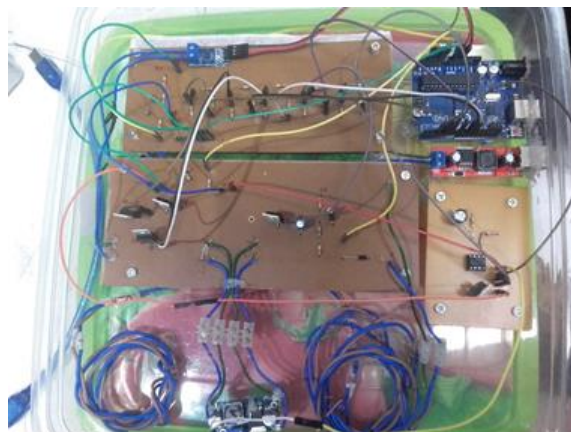

Fig. 9. Prototype implementation

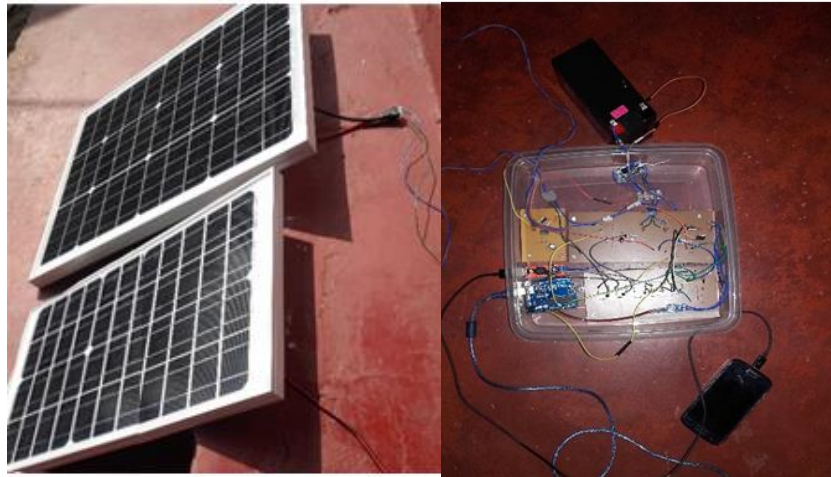

Fig. 10. Testing of the implemented prototype

6 . RESULTS

Duty cycle which must give to the converter is decided by comparing the current solar panel voltage and pilot solar panel voltage to maintain the MPPT algorithm. The buck converter module is used in the implementation and created duty cycle according to the MPPT algorithm is given to the feedback pin of the LM2596 IC in the module.

Changing the PWM from the control circuit, measured the variation of the current in the charging path.

After battery voltage reached 12.6 V, it disconnected the MPPT process and then the battery charged by getting current as required. When the battery voltage become 12.9 V battery charging path is disconnected.

To charge only the 12 V/7 Ah battery, it took nearly 9 hrs without MPPT, and it gets almost 8 hrs to charge the battery with the implemented system (in a sunny day).

Table 1. Measured current with MPPT and without MPPT

V_{oc} of the pilot panel(V)	Current (A) (Without MPPT)	Current (A) (With MPPT)
19.25	0.52	0.63
18.16	0.47	0.59
17.5	0.42	0.44
15.52	0.22	0.24
15.23	0.21	0.24
16.7	0.4	0.43
17.25	0.42	0.45
18.61	0.49	0.6
19.35	0.54	0.64
18.75	0.51	0.63

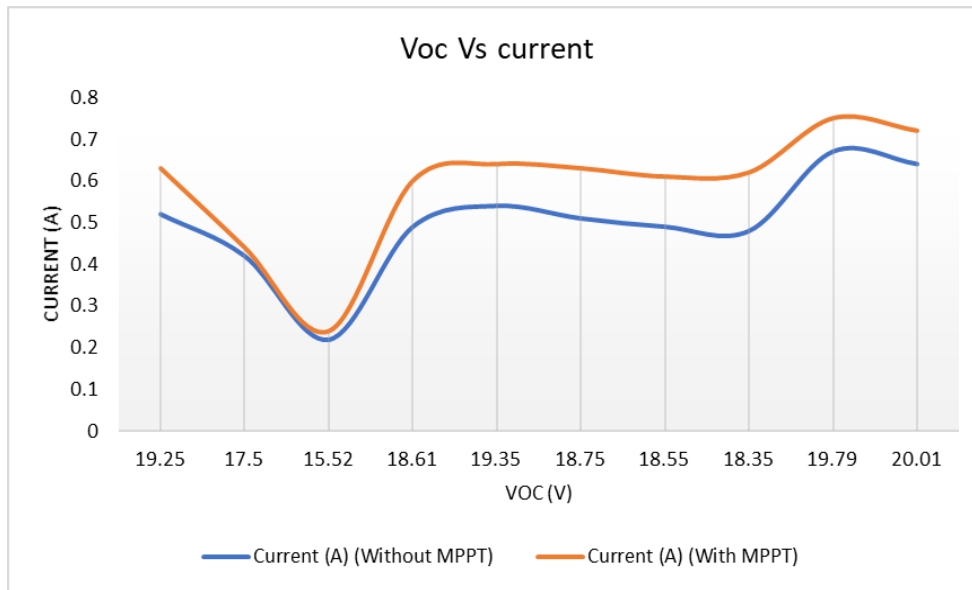

Fig. 11. Current variation at the MPPT process

Charging the mobile phone:

Mobile phones are charged using a buck converter with a fixed 5 V output, and readings were collected using two smartphones with the Li-ion batteries of 2600 mAh, 9.88 Wh, and 6.84 Wh.

The 9.88 Wh battery is charged by getting 0.49 A from the solar panel or 12 V battery.

The 6.84 Wh battery is charged by getting 0.41 A from the solar panel or 12 V battery.

When both phones connected at once module pass the current of 1.03 A, to fully charged the mobile phone with 6.84 Wh battery, it takes nearly 5 hrs.

7 DISCUSSION

Selected buck converter module to step down the solar panel voltage to the battery can pass only 3 A maximum current but when current reaches to 1 A module become heated. Converter module which used for phone charging also has 3 A maximum current rating. But when it drags 1.1 A, it becomes heated. Heat sink needs to be used for both modules. Since selected battery (12V, 7 Ah) is limited in the capacity, it cannot use for a longer time. So that battery is selected only for the implementation purpose.

Use of buck-boost converter would give optimum results for the system as it gives more benefits even at the low voltage output from the panel. However, at the boost range, it reduces the current output.

In the MPPT process, while it gives the PWM signal to the LM2596 IC in the converter module when the voltage at the feedback pin is lower than the 1.23 V reference value, it increases the output power. Also, when the voltage is above 1.23V reference, then it reduces the output power. It is needed to keep feedback voltage range between 1.18 V and 1.28 V. If it is not in the given range, then there is no current flowing through the charging path.

In this system, FOCV method is used as the MPPT algorithm, and as the cell, a separate pilot solar panel is used for the implementation. If this module is fabricated as a commercial product, it can use only one cell for one setup.

When monitoring the battery, the load side and the charging side always need to be disconnected to get the battery's open-circuit voltage. This will create considerable power loss since this happens every half minute. By applying a proper method to get the battery SOC at the charging, the above problem can be eliminated.

8 CONCLUSION

In stand-alone PV systems, MPPT exports the maximum power from the solar panel, without considering the load conditions. Therefore, the system can be cut off when it does not connect to a sufficient load. When considering the battery's charging, it cannot always charge with the MPPT because it can only give the high current at the bulk charging region of the battery charging curve while in the other areas of the curve it can provide the normal power from the solar panel for charging.

The proposed system uses a control circuit to manage the solar panel's output power by checking the load condition and effectively charging the battery. In results it clearly shows with MPPT charging, current of the battery is significantly increased. Therefore, the stand-alone PV system is used to design a mobile device charger more efficiently.

It shows that using this mobile device charger devices can be fully charged with the acceptable time where electricity from the national grid is inaccessible. Results also show that 12 V DC bus also can be used as an emergency charger for mobile devices.

REFERENCES

- Agrawal, S., Tiwari, G.N. (2011) Energy and exergy analysis of hybrid micro-channel photovoltaic thermal module. *Solar energy* 85 (2), 356-370
- Atallah, A. M., Abdelaziz, A. Y., Jumaah, R. S., (2014), Implementation of perturb and observe MPPT of PV system with direct control method using buck and buck boost converters. *Emerging Trends in Electrical, Electronics & Instrumentation Engineering: An international Journal*, Vol. 1.
- Ahmad, J., Kim, H. J., (2009). A Voltage Based Maximum Power Point Tracker for Low Power and Low Cost Photovoltaic Applications, *s.l.: International Journal of Electrical, Computer, Energetic, Electronic and Communication Engineering*.
- Anon., n.d. *Arduino Uno Rev3*. <https://store.arduino.cc/usa/arduino-uno-rev3>
- Faranda, R., Leva, S., (2008), A Comparative Study of MPPT techniques for PV Systems. Milano, ITALY, s.n.
- Jyothi, V.M., Muni,V.,Lalitha, S. V. N. L., (2016), An Optimal Energy Management System for PV/Battery Standalone System. *International Journal of Electrical and Computer Engineering (IJECE)*, Vol. 6,P 2088-8708
- Lopez, J., Seleme, S. I., Donaso, P.F., Mendes, M. S., Morais, L. M. F., Cortizo, P., (2013). Methodology for the design of a stand-alone photovoltaic power supply. *Ingeniare. Rev. chil. ing.* , vol.21(3).p 380-393
- Pathare, M., Shetty, V., Datta, D., Pai, S., (2017), Designing and Implementation of Maximum Power Point Tracking(MPPT) Solar Charge Controller, *International Conference on Nascent Technologies in Engineering (ICNTE)*

Siddhant, K., (2014). Implementation of fractional open circuit voltage mppt algorithm in a low cost microcontroller, Rourkela: s.n.

Ulaganathan, M.K.D., Saravanan, C., Chitranjan, O.R., (2014), Cost-effective Perturb and Observe MPPT Method using Arduino Microcontroller for a Stand-alone Photo Voltaic System. *International Journal of Engineering Trends and Technology (IJETT)* , Vol 8.

Xiong, X., (2016). Closed-Loop Design for Standalone Photovoltaic-Battery Hybrid Power System. *Journal of Electrical and Electronic Engineering.*, Vol. 4(5), 131-138.